

# SIXTEEN CITIES

1 of 3

## 2011 TOUR RIDER

Revised 6/2011

Thank you for accommodating us with these details.  
If you have any questions, please use the appropriate contact below.

---

Thank you for this opportunity to partner with you. Our desire for this event, as we are sure is yours, is to provide a quality, fulfilling and professional musical experience. The information in this document is necessary to accomplish our common goal.

Thank you in advance for taking the time to read each section carefully. It is crucial to the success of the event that we agree on the importance and execution concerning the following requests. Communicating our needs and expectations in advance will eliminate any mutual frustrations or misunderstandings on either part, and will ensure all necessary details, schedules and responsibilities have been mutually approved, arranged and settled.

Please ask if you have any questions. It is our sincere goal to never appear "demanding" or "high-maintenance". Our desire is to approach every opportunity with excellence, humility and professionalism. We see this day as much more than "you bringing us" or "us bringing music", but rather "us partnering together." Thanks again for the privilege of working with you!

### **Sixteen Cities (Herein 16C) is:**

Josiah Warneking: Keyboards and Vocals  
Josh Miller: Electric Guitar and Vocals  
Chad McCutchen: Drums and Percussion  
Joel Warneking: Bass Guitar and Vocals

### **Concert Advancement:**

Josh Miller  
3300 NW 185th Ave #261  
Portland, Or. 97229  
P: 503-679-1082  
E: [josh@sixteencities.com](mailto:josh@sixteencities.com)

### **Management:**

Josh Miller  
3300 NW 185th Ave #261  
Portland, Or. 97229  
P: 503-679-1082  
E: [josh@sixteencities.com](mailto:josh@sixteencities.com)

### **Booking:**

Chris Blaney  
Converge Music  
201 22<sup>nd</sup> Avenue North – Suite C  
Nashville, TN 37203  
P: 615.369.7799 F: 615.915.4821  
E: [chris@convergemusic.com](mailto:chris@convergemusic.com)

### **ACCOMODATIONS AND HOSPITALITY:**

There will be a total of five to seven (5-7) members in our traveling party, **four (4) players, one (1) sound engineer, and occasionally, 1-3 wives.** We will be sure to let you know how many will be attending your event before day of show.

GREEN ROOM: Please include HEALTHY snacks and drinks for five to seven (assorted juices, bottled water, and snacks (healthy dry-goods, trailmix, etc.). Please provide non-perishable snacks that can be taken at the end of the night. If possible, please provide comfortable chairs or couches in the green room.

MEALS: Thank you again for supplying meals. As the nature of our work, it is common to have the same meal routinely catered. In an attempt to maintain health on the road, we request that catered or home cooked meals be kept relatively healthy to include vegetables, lean meats, and salads. We would love to avoid heavy meals such as lasagnas, pizza, fast-food burgers, etc. We always try to accommodate your time and schedule concerning meals; as such many times a simple meal per diem may be negotiated. In such cases the typical per diem is: \$15 per person for lunch; \$20 per person for dinner.

HOTEL: Please provide two (2) to three (3 – if the wives are traveling) non-smoking double rooms (Hampton Inn or Holiday Inn Express or like), with corridor/indoor entrances (No outdoor, motel like entrances). Please reserve rooms under "**Sixteen Cities**". Please ensure rooms are prepaid in full prior to the band's arrival. Thank you for having room keys available for us before the event begins: Checking in after the event, late at night, is not always a fun experience, unless front desk cookies are involved. Please contact management for any alternative housing arrangements (host homes or bed & breakfast type housing) one month prior to the event and make sure the rooms/homes are FREE OF PETS! (NO DOGS OR CATS DUE TO BAND ALLERGIES!) Under certain routing circumstances, we may negotiate a hotel buy-out for accommodations.

VOULUNTEERS: Please have 3 healthy & strong adult volunteers to help load-in gear and merchandise upon our arrival.

### **MERCHANDISE:**

It would be great to have an area of the lobby, or other suitable place, to sell resources. We will need two (2) 8' tables and one (1) or two (2) responsible, adult volunteers to help oversee the table. The volunteers will, at times, be handling large amounts of cash and must be responsible. With this consideration please make sure at least one of the volunteers is an older adult, and is comfortable with these requirements.

CD AND RESOURCE SALES: Sixteen Cities shall have the sole and exclusive right, but not the obligation, to sell resources including, but not limited to, recorded music and resources in connection with, and at, the event. The receipts from such sales shall belong exclusively to Sixteen Cities.

# SIXTEEN CITIES

2 of 3

## 2011 TOUR RIDER

Revised 3/2011

### **CANCELLATION:**

Sixteen Cities enters this agreement under good faith and with a committed spirit. Seldom times, extraneous circumstances require an event sponsor (promoter/buyer) to cancel. Because our financial livelihood is based on concert events, it is important that some requirements be placed to avoid unnecessary cancellations.

Therefore following cancellation policy is in effect:

**2 months prior to event** - the sponsor will be required to pay 50% of total honorarium.

**2 weeks prior to event** - the sponsor will be required to pay 100% of total honorarium.

### **IMPOSSIBILITY OF PERFORMANCE:**

It is Sixteen Cities's desire and intention to appear at every contracted engagement. If we are prevented from performing their obligations under this Agreement due to illness, unforeseen emergency, or any other conditions beyond our control, which make it reasonably impractical for the musicians to attend, Sixteen Cities will not have any liability for expenses or losses incurred by the Sponsor. We shall endeavor to suggest a comparable alternate musician that is acceptable to the Sponsor OR reschedule the event for a future, mutually agreeable date. That failing, the deposit shall be returned to the Sponsor and neither Sixteen Cities, Converge Music, Eagelmont Entertainment nor Centricity Music shall have further liability or obligation to the Sponsor.

### **TECHNICALS:** 22 lines total

Please provide a knowledgeable house contact capable of operating all house gear, administering sound check and the performance, and that is authorized to direct stage details. Please provide all cabling and microphones to accommodate the attached input list. Sixteen Cities will provide all backline and instruments, unless backline is required under circumstance (festivals, fly dates and multiple artist bills).

Please strike and clear stage of all non-essential instrumentation except what will be needed during the event. If gear cannot be cleared, please have the gear covered or draped. Please have stage set up and wired to begin sound check by the scheduled sound check start time.

We will need at least a 24-channel professional build audio console, with 22 free and available inputs, adequate reverb and compression units, and Phantom power available for all lines. The Input list is located on the attached stage plot. The house system must be adequate to cover the entire venue, including a minimum of four (4) sub boxes and four (4) main boxes.

We will need **front stage AC POWER**. Could we also have five (5) guitar stands and two (2) boom stands on stage.

### **MONITORS AND MIXES:**

Sixteen Cities will provide their own wireless in-ear packs and transmitters to patch into the house console. Please provide four (4) separate monitor mixes, independent of the FOH mix.

### **SOUNDCHECK:**

Please allow one hour before doors for soundcheck. Please keep room clear of public while band is checking.

### **LIGHTING:**

Concerning lighting, please feel creative freedom while staying within the context of the song and performance.

### **BACKLINE FESTIVAL/FLY DATE REQUESTS:**

**(1 Drum Kit, 1 Bass Amp, 2 Guitar Tube Combo Amps, 1 Keyboard/Controller)**

Drums: Yamaha Maple Custom or DW 4 pc. Kit – One 20" or 22" Kick, One 16" Floor tom, One 12" Rack tom, One 14" snare, hats, 2 crash cymbals and ride

Bass: Ampeg SVT Classic Tube head, Ampeg SVT 810 Cabinet

Guitar(2): One Vox AC-30 and One Fender Deville (No modeling amps)

Keyboard: One weighted 88 key Midi capable keyboard

# SIXTEEN CITIES

## 2011 TOUR RIDER

Revised 3/2011

### ICON LEGEND

- DI DI Line
- :: AC Quad
- ⊗ Microphone
- ⊙ Stool

## STAGE PLOT & INPUT LIST

### Concert Advancement Contact:

Walt Smith  
 Eaglemont Entertainment  
 135 2<sup>nd</sup> Avenue North  
 Franklin, TN 37067  
 P: 910.286.8836  
 E: [walt@eaglemontentertainment.com](mailto:walt@eaglemontentertainment.com)

### NOTES:

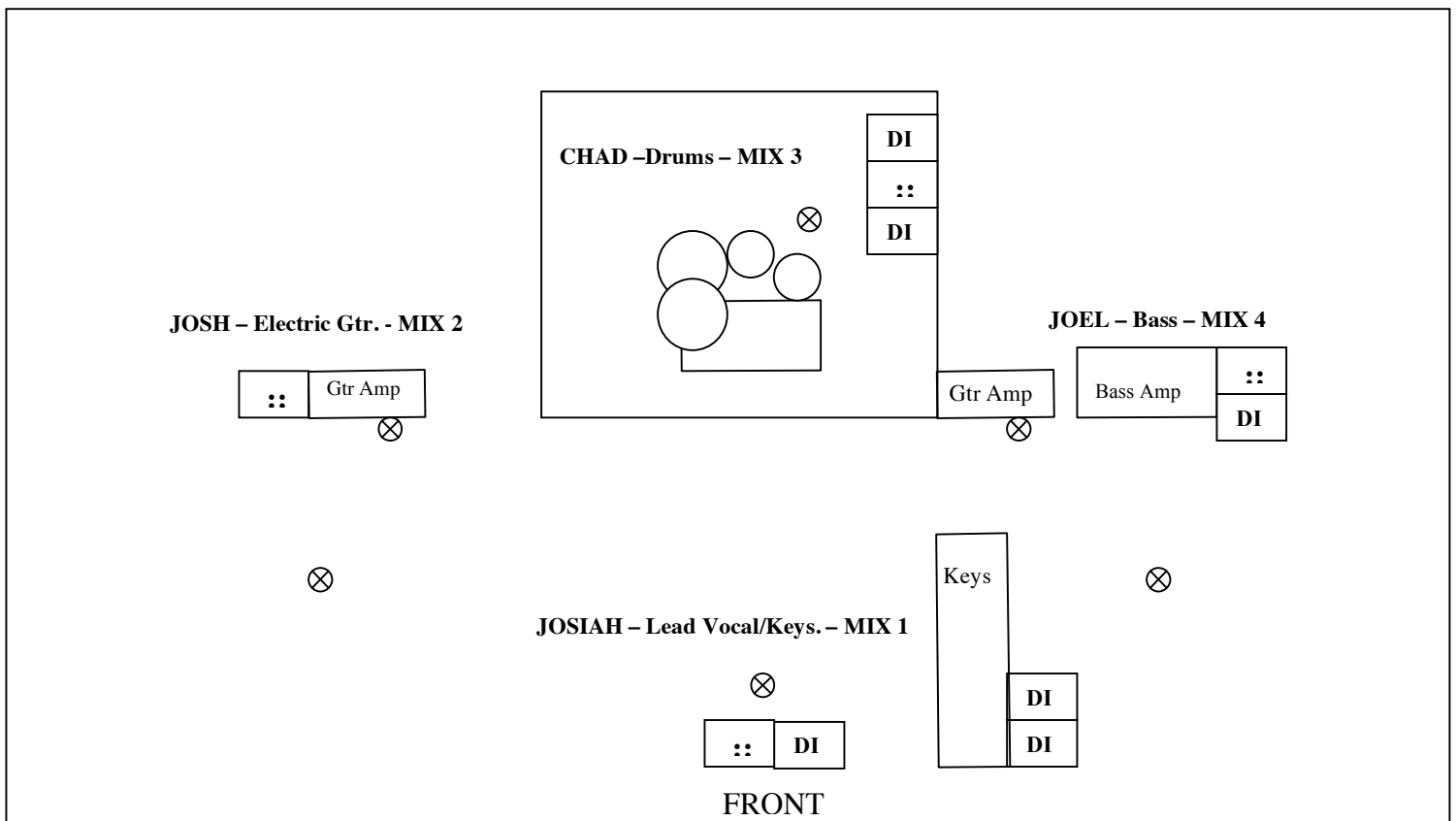

### 16C Monitor Call:

Mix 1: Josiah  
 Lead Vocal  
 Keys

Mix 2: Josh  
 Guitar

Mix 3: Chad  
 Drums

Mix 4: Joel  
 Bass

CH	INPUT	NOTES	CH	INPUT	NOTES
1	Kick		12	Ac. Guitar	
2	Snare 1		13	Box Hi	
3	Snare 2		14	Box Low	
4	Hat		15	Keys Left	
5	Rack tom		16	Keys Right	
6	Floor tom		17	Josh Vocal SR	
7	OH Left		18	Josiah Vocal	
8	OH Right		19	Joel Vocal SL	
9	Bass DI		20	Click	
10	Guitar Amp 1		21	Track 1	
11	Guitar Amp 2		22	Track 2	